



# CHLORITROL® CL with C100A Liquid Hypochlorite Injection System

## INSTALLATION & OPERATING INSTRUCTIONS

### SAFETY INSTRUCTIONS



Before using any Fluid Metering, Inc. product read the following safety instructions as well as specific product specifications and operating instructions.



**Warning!** Fire, electrical shock or explosion may occur if used near combustibles explosive atmosphere, corrosive air, wet environment or submerged in fluid.



**Caution:** Fire, electrical shock, injury and damage may occur if not used in accordance with Fluid Metering, Inc. specifications and operation instructions.

- Disconnect electrical power before checking pump for any problems.
- Connect motor, speed controllers, or any other electrical devices per Fluid Metering Inc. specifications. Any unauthorized work performed on the product by the purchaser or by third parties can impair product functionality and thereby relieves Fluid Metering, Inc. of all warranty claims or liability for any misuse that may cause damage to product and/or injury to the individual.
- Power cables and leads should not be bent, pulled or inserted by excessive force. Otherwise there is a threat of electrical shock or fire.
- Replace any inline fuses only with fuse rating as specified by Fluid Metering, Inc.
- When pump/drive is under operation, never point discharge tubing into face or touch any rotating components of pump.
- In a power down thermal overload cut-in condition, disconnect power to pump. Always allow a cool down period before restarting; otherwise, injury or damage may occur.
- For 30 seconds after power is removed from pump/drive: do not touch any output terminals. Electrical shock may occur because of residual voltage.
- **Install only in ventilated spaces**
- **Unit should be sheltered from outdoor elements**
- Do not put wet fingers into power outlet of unit.
- Do not operate with wet hands.
- Do not operate drive assemblies that require a hard mount (to be bolted down) unless they are mounted per Fluid Metering, Inc. specifications, if not injury may occur and/or damage to unit.
- Do not touch any rotating pump or motor components: injury may occur.
- Do not run pump dry, unless designed for that service. Running dry is harmful to the pump, and will cause excessive heating due to internal friction.
- Check pump rotation and inlet/outlet pump port orientation before connecting power to pump. If not injury may occur.
- When pulling out cords from outlets do not pull cord, grasp plug to prevent plug damage or electrical shock.
- Fluid Metering, Inc. Drive Motors become HOT and can cause a burn. **DO NOT TOUCH!**

### OVERVIEW:

**Congratulations.** Your Chloritrol® CL System from Fluid Metering Inc. is the newest patented innovation in 50 years for accurate, low maintenance injection of sodium hypochlorite for water and wastewater treatment. FMI's CL, along with it's CTS Chemical Treatment System for caustic soda, are the easiest chemical feed systems for water and waste treatment in the world.

The patented Chloritrol® CL & CTS systems eliminate check valves and/or peristaltic tubing typically present in traditional hypochlorite metering systems, which are the primary sources of downtime and frequent maintenance. The CL & CTS Systems will never lose prime, even against pressure, or air lock. The Chloritrol® CL system consists of the **CL Pump Module** and **C100A Variable Speed Controller**.

The **CL Pump Module** is a unique valveless duplex FMI CeramPump® and an FMI RO "sipper" pump direct coupled to a single variable speed drive motor. The high-pressure CeramPump® injects the hypochlorite directly into the main water stream, while the RO "sipper" pump removes any gas generated because of chlorine out-gassing, eliminating "gas lock" and/or loss of prime.

The **C100A** Variable Speed Controller from Fluid Metering, Inc. is specifically designed to interface with the **Chloritrol® CL Pump Module**. This controller provides a variable 0-90 VDC power source, which is controlled either manually using a panel mounted rotary dial, or electronically via a 4-20 mA control input.\*



Chloritrol® CL Pump Module  
and C100A Variable Speed Controller

\* Other commercially available controllers may work, however we recommend contacting FMI for details.



## CL SPECIFICATIONS

Supply Voltage: 0-90 VDC (Supplied by C100A Controller)

CL Supply: 1/4" NPT female

CL Recirculation return: 1/4" NPT female

CL High Pressure outlet: 1/4" NPT female

Output Volume: CL1: 6.5 GPH max.

CL2: 15 GPH max.

Output Pressure: 125 psi max.

Environment: Humidity: 100% RH non-condensing

Temp: non-freezing to 104°F

Enclosure: Fiberglass

Dimensions: 15 1/2" x 13 3/8" x 6 3/4"

Weight: 18.6 lbs. (8.4 kg.)

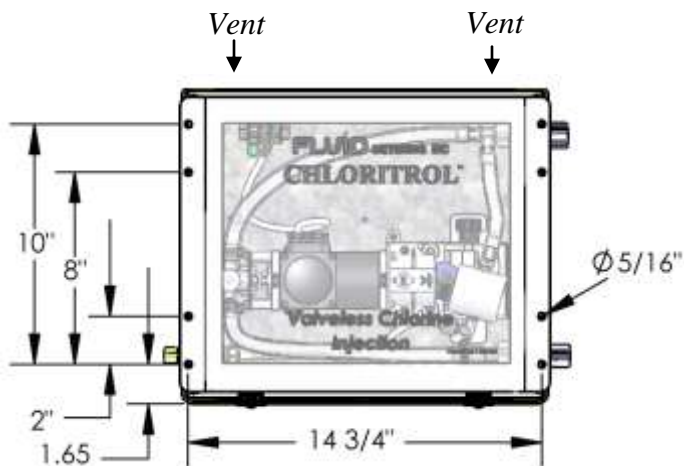

**Diagram 1**  
Mounting Holes

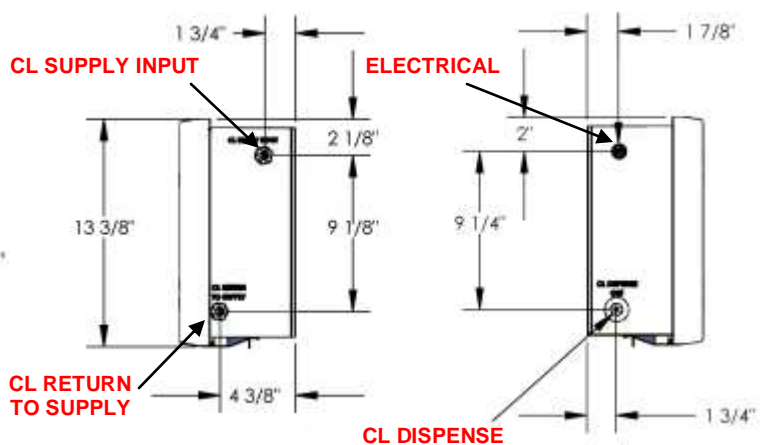

**Diagram 2**  
(Right Side)

**Diagram 3**  
(Left Side)

**IMPORTANT NOTE:** There are two (2) vent holes located at the top front of the enclosure (under the upper lip of the enclosure cover). Do not close, seal, or obstruct these vent openings. They are designed to prevent hazardous gases from building up in the enclosure over time. See **Diagram 1**.

## ELECTRICAL

On the upper left side of the Chloritrol® CL enclosure is a 7/8" conduit opening for the electrical supply (0-90 VDC source from the C100A or FMI approved customer supplied voltage controller). **Note: See page 5 "Wiring Procedure" for additional information regarding wire sizing.**

1. With the power off, and the manual speed dial turned fully counterclockwise to the "0" position, connect the C100A to the 120 VAC power source.
2. Connect the C100A Variable Speed DC Controller to the Chloritrol® using 3 conductor cable.
3. If electronic speed control is being used, connect the 4-20 mA source (typically a sensor or analyzer), to the 4-20 mA input of the C100A.

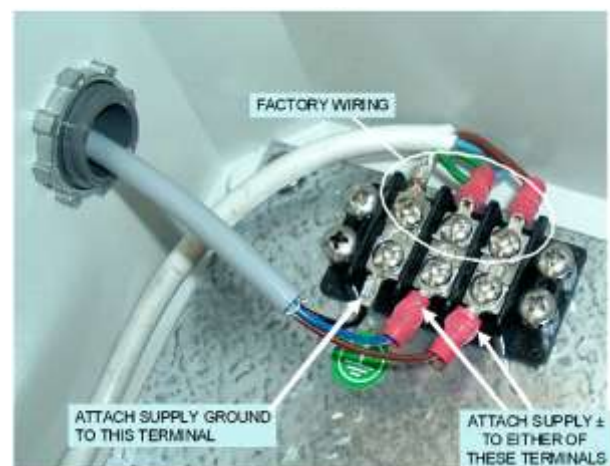

**Diagram 4**  
Terminal Wiring



## FLUIDIC CONNECTIONS

1. Connect the supply tubing from the hypochlorite supply vessel to the 1/4" NPT female **CL Supply Inlet** fitting of the Chloritrol CL. Supply tubing should be 1/4" to 3/8" ID semi-rigid translucent tubing, LDPE (low density polyethylene) or equivalent. **Refer to Fluidic Overview Diagram 5.**

**Important Note:** Do not use any fittings having Buna-N seal elements. Only Viton® should be used.

2. Connect the Return tubing from the 1/4" NPT female **CL Return** back to the supply vessel. Return tubing should be 1/4" to 3/8" ID semi-rigid tubing, LDPE (low density polyethylene) or equivalent. **Refer to Fluidic Overview Diagram 5.**

3. Connect 1/4" OD tubing (semi-rigid suggested), from the **CL Dispense** (1/4" NPT female) to the point of chlorination, typically the groundwater well or water main.

Chlorine Analyzer  
or other 4-20 mA source

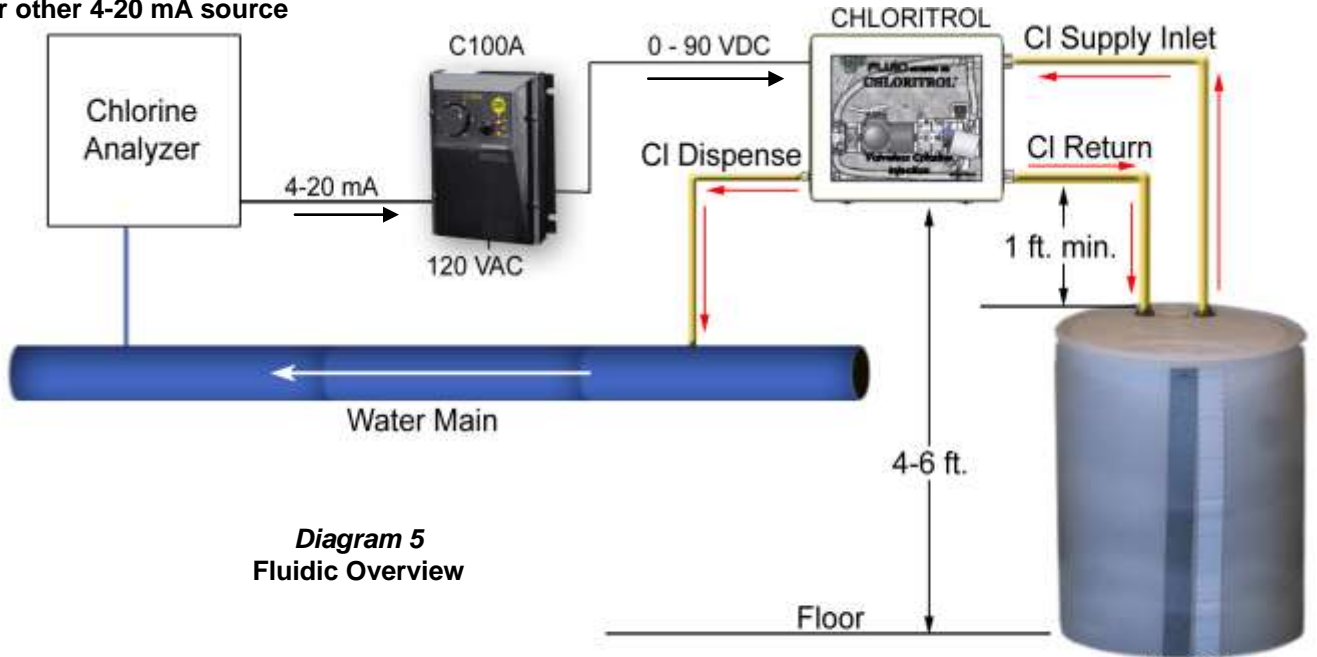

**Diagram 5**  
Fluidic Overview

## START UP / PUMP CALIBRATION

### Mechanical Adjustment:

**Note:** Your CL unit comes factory set at 50% flow.

By adjusting the angle of the high pressure pump head (pump head on right side of drive) using the adjustment knob, piston displacement can be increased and decreased, which in turn will vary flow rate. **Diagram 6** shows the minimum (0%), maximum (100%), and factory set (50%) pump head positions.

**Electronic Adjustment:** The C100A Variable Speed Controller varies pump speed and has both manual and electronic control modes.

For manual speed adjustment, set the C100A ON/OFF switch to the "ON" position and set the rotary dial to 6. Turn On and measure discharge flow. Adjust flow as necessary.

For speed control from an external 4-20mA source, set the ON/OFF switch to the "AUTO" position.

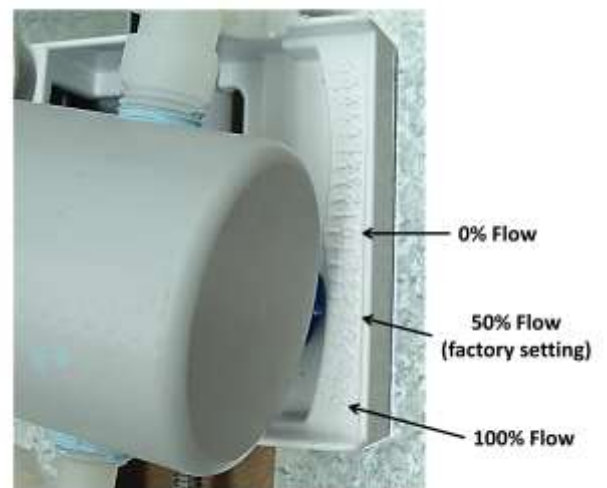

**PUMP HEAD ANGLE**  
(Displacement Adjustment)

**Diagram 6**



# Calibration Reference Charts

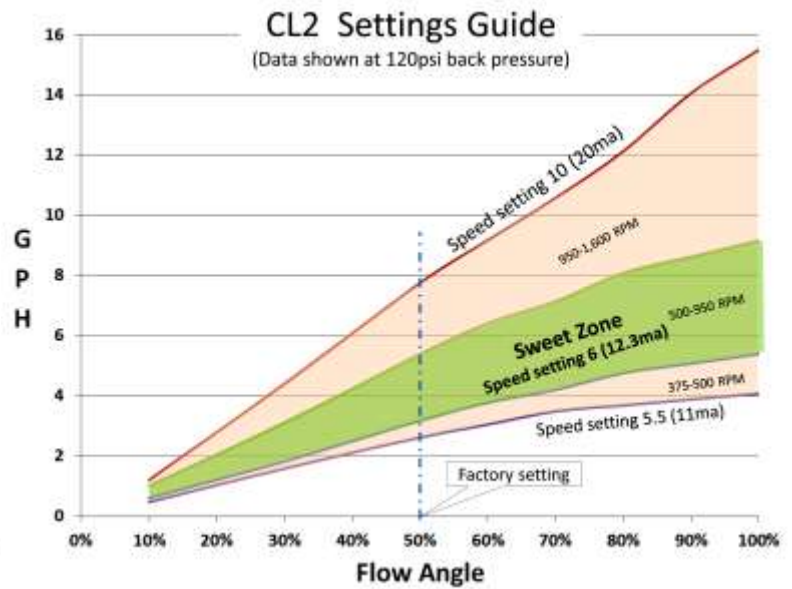
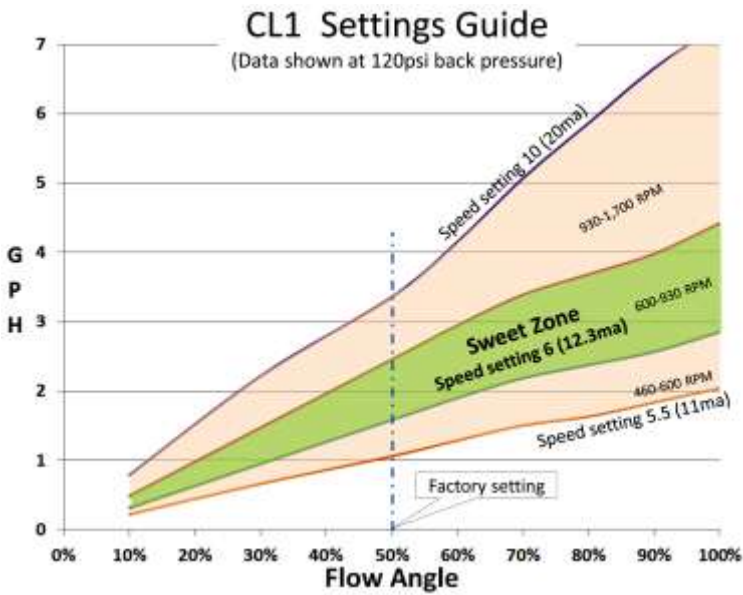

\* Your CL unit comes factory set at 50% flow

## Maintenance

### Periodic:

- Rinse the piston where it enters the seal using the small squirt bottle provided. Simply use water. This will help to eliminate any build up of crystals that may damage seals. Perform this procedure once a day, week, or whenever you are in the pump house.
- Check for leaks, drips, .. etc. Wipe clean as necessary.

### Scheduled: 4 months or 1000 hrs.

- Check for leaks at all fittings and pump head. Change seals and/or fittings if necessary.
- Grease piston drive pins using supplied syringe. Apply a small glob of grease to the piston drive pin where it enters the drive bearing.
- Wipe box and components down with a cloth, spraying a light mist of protectant oil, such as Silikroil, on all metal components to help inhibit corrosion.

### Extended Shut Down or Storage:

Always flush your Chloritrol® CL unit with fresh water for 10 minutes prior to any extended shut down to ensure easy startup later. Pump units that are not flushed prior to extended shut down will probably seize and need to be returned to FMI for rebuild.

### Internal Top View

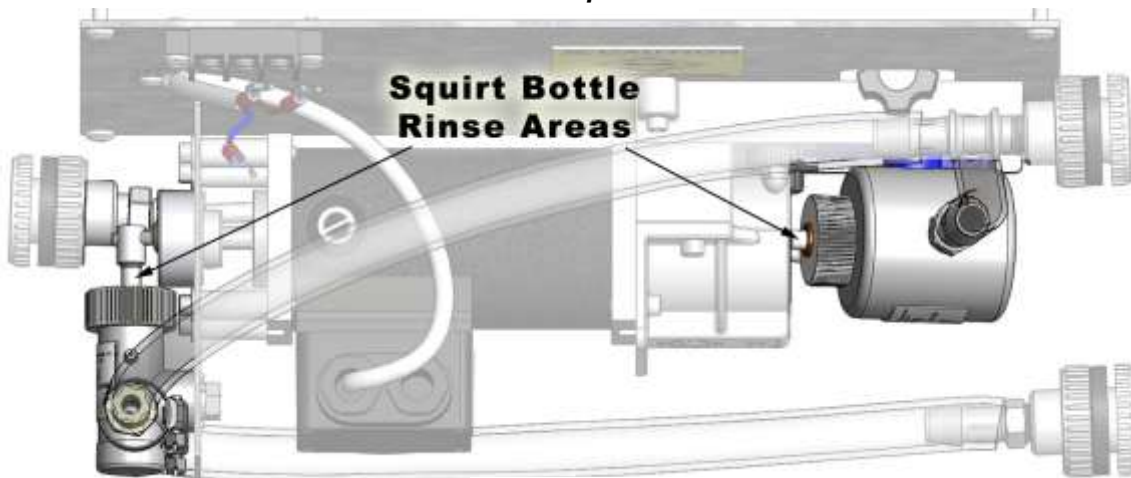

# C100A Variable Speed DC Controller

## GENERAL

The FMI C100A Variable Speed DC Controller is designed to operate with FMI Variable Speed CL and CTS Drives.

The C100A features both manual speed adjustment ("ON" position) using a front panel mounted rotary control, as well as electronic speed control ("AUTO" position) via a 4-20mA signal from an external source (sensor, analyzer, process controller.. etc).

The C100A incorporates transient voltage protection with adjustable current limit and AC fuse for protection. It features adjustable minimum and maximum speeds along with adjustable acceleration and IR compensation.

The electronics are housed in a gasketed NEMA 4/12 enclosure suitable for wall mounting.

IMPORTANT: The C100A Control Unit is factory calibrated for optimum performance. Adjusting internal pots may void



## MOUNTING PROCEDURE

The C100A has two (2) mounting slots located on flanges on each side of the chassis as shown in **Diagram 7 (right)** suitable for wall or vertical panel mounting. It is recommended that all four (4) mounting slots be utilized for maximum stability.

There are two 1/2" NPT female conduit fittings located at the bottom of the C100A enclosure for connecting electrical conduit. Allow adequate access to the area surrounding these fittings for connecting electrical conduit.

## C100A CONTROLLER

Supply Voltage: 120 VAC 50/60 Hz, 0.5 Amp

Fuses: The C100A is provided with a fuse in the AC line (P1-11). This fuse is sized to open in the event of a shorted armature or if an armature line is shorted to ground.

Speed Control Input via 3 position ON/OFF switch:

- 1) "ON" position = Manual (Rotary Dial)
- 2) "AUTO" position = Electronic (4-20 mA) source

Dimensions: 7.0" H x 5.53 W  
Enclosure: NEMA 4/12

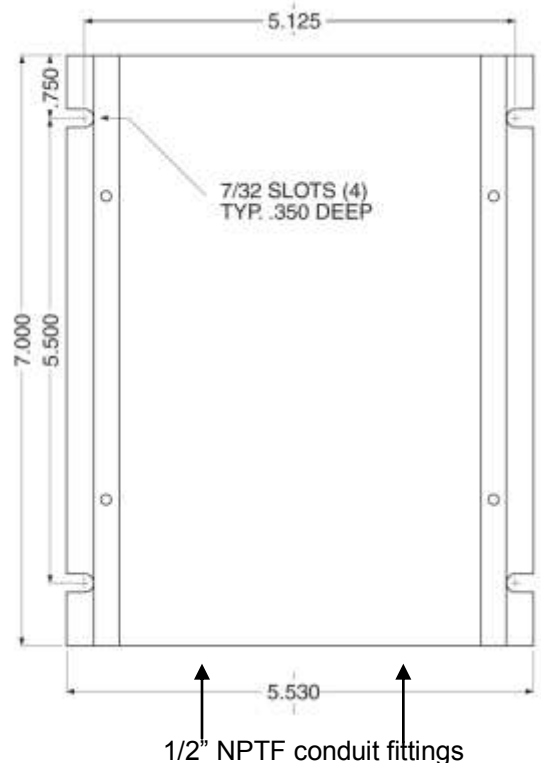

**Diagram 7**  
**Mounting Diagram**



## WIRING PROCEDURE

- 1) Remove the four (4) cover screws to remove the cover and gain access to the terminal strip.  
**Note:** When removing the cover, take care not to damage the cover gasket or the wires connecting the cover controls with the main circuit board.
- 2) If an external 4-20 mA control source is used, (typically a sensor, analyzer, or PLC etc.), connect the 4-20 mA output of this device to the +1 and -2 terminals as shown below.
- 3) After all wiring is complete, replace the cover. Take care to align the gasket and torque down the four (4) cover screws such that the gasket is evenly compressed and seals properly.

**Important Note:** Trimpots are factory tuned for optimal performance. Adjustments in the field should only be made with the guidance of FMI support personnel or performed by an authorized FMI factory representative. Before performing any trimpot adjustments, contact FMI factory.

## WIRING NOTES:

1. Size all wires that carry drive motor or line current to handle currents as specified by national state, and/or local codes. All other wires may be #18 AWG or smaller as permitted by local code.
2. Separate control wires from all DC Drive and AC line wires when routed in conduits or in wire trays. There are two (2) threaded 1/2" NPT holes in one endplate, located near the terminal strip, for this purpose.
3. The C100A is provided with a fuse in AC line 1 (P1-11). This fuse is sized to open in the event of a shorted drive armature, or if the 0-90 VDC line to the drive motor is shorted to earth ground. As long as the 120 VAC input is connected properly, there is no additional fusing required.

## Wiring Diagram

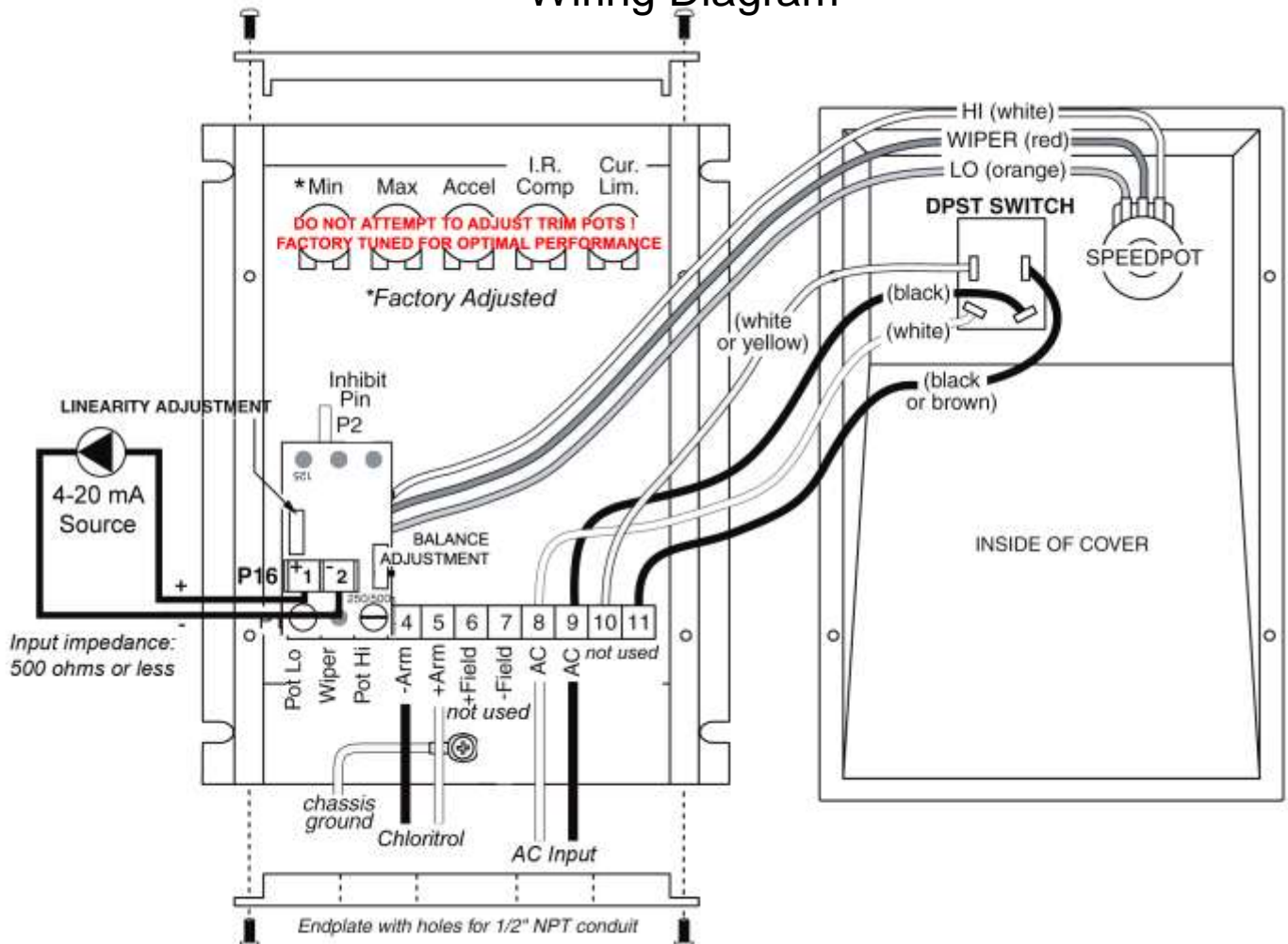

# CL PARTS LIST

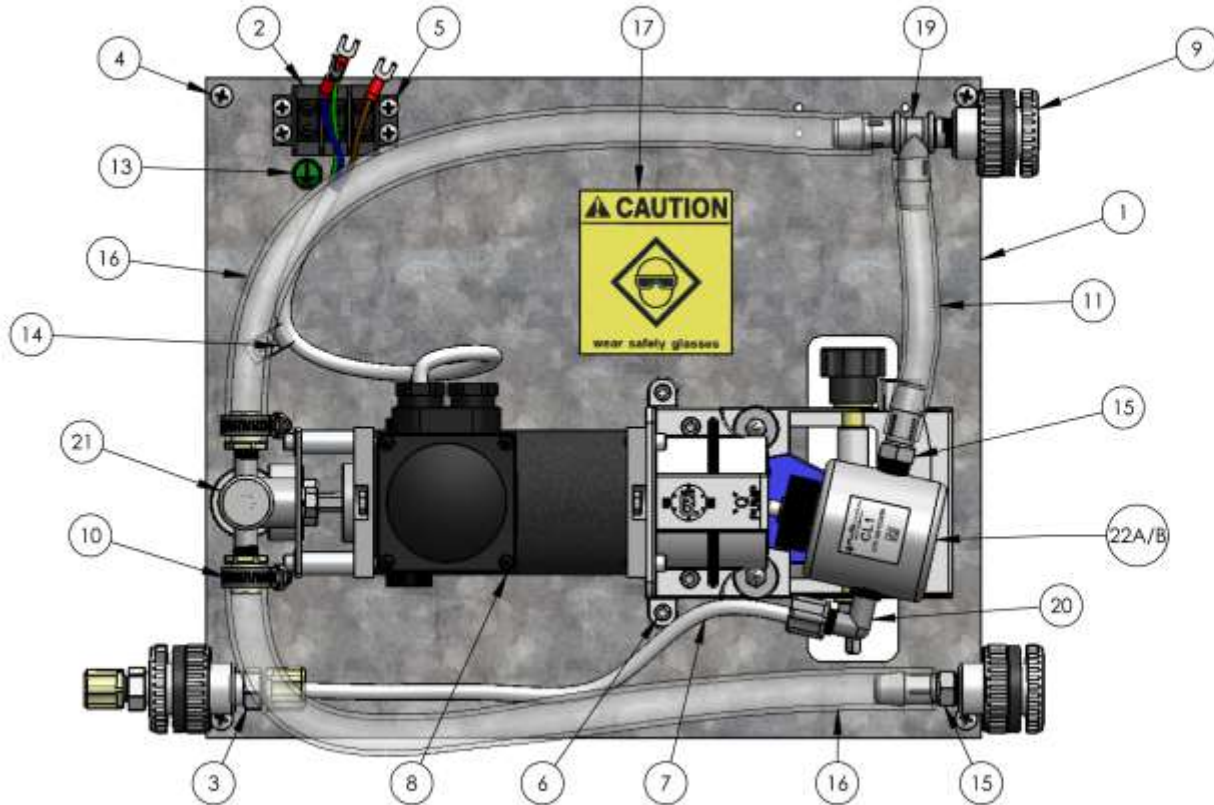

ITEM NO.	PART NUMBER	DESCRIPTION	QTY.
1	300961	BACK PLATE	1
2	111070	TERMINAL BLOCK	1
3	111071	¼ NPT X ¼ COMPRESSION PVDF FITTING	2
4	110147-6	SCREW, PHP 10-32 X 3/8"	4
5	110655-8	SCREW, PHP 8-32 X 1/2"	5
6	110290-14	SCREW, SHC 8-32 X 7/8"	2
7	300989	TUBE HIGH PRESSURE OUTLET	1
8	200666	DUPLEX DRIVE	1
9	300984	MODIFIED BULKHEAD FITTING	3
10	110303	HOSE CLAMP	2
11	300986	TUBE RESERVOIR	1
12	301004	GASKET (INSIDE ENCLOSURE COVER)	1
13	110986	GROUND LABEL	1
14	110304	CORD LOCK	1
15	111077	FITTING 1/4" NPT TO 1/2" HOSE BARB	1
16	300987	TUBE INLET/OUTLET	1
17	111119	CAUTION LABEL	1
18	300993	SCREENED ENCLOSURE	1
19	301062	MODIFIED FITTING	1
20	111079	FITTING ½" NPT TO ¼" COMPRESSION EL	1
21	200668	RO PUMP HEAD MODULE ¼" DIA	1
22A	Q1CV	Q PUMP HEAD ¼" DIA	1
22B	Q2CV	Q PUMP HEAD 3/8" DIA	1
23	200768	SPARE PARTS KIT CL1	1
24	200769	SPARE PARTS KIT CL2	1

RECOMMENDED SPARE PARTS CL1: 21, 22A, 23  
CL2: 21, 22B, 24



## CL-CHLORITROL® LESS CONTROLLER



## RECOMMENDED SPARE PARTS KITS 200768(CL1) & 200769(CL2)

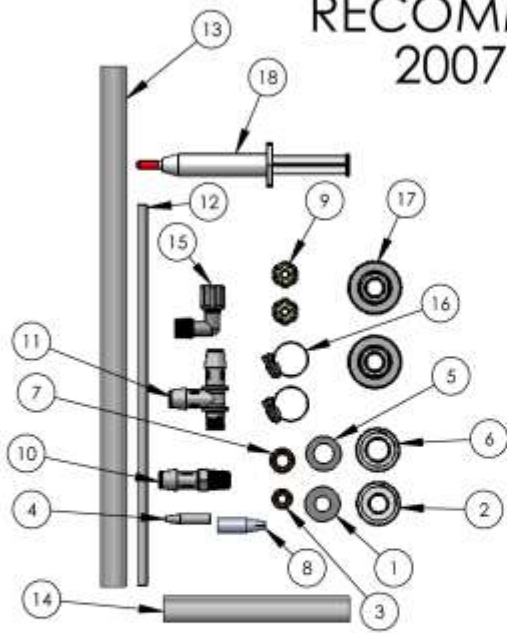

ITEM NO.	PART NUMBER	DESCRIPTION	QTY CL1 KIT	QTY CL2 KIT
1	301075-1	GLAND WASHER 1/4"	2	1
2	R406-1CS	GLAND NUT TYPE RP	2	1
3	301045	CARTRIDGE SEAL 1/4"	2	1
4	500071	TOOL 1/4" LIP SEAL INSTALLATION	1	1
5	301075-2	GLAND WASHER 3/8"	0	1
6	R406-2CS	GLAND NUT 3/8"	0	1
7	301046	CARTRIDGE SEAL 3/8"	0	1
8	500080	TOOL 3/8" LIP SEAL INSTALLATION	0	1
9	111071	1/4 NPT X 1/4 COMPRESSION PVDF FITTING	2	2
10	111077	FITTING 1/4" NPT TO 1/2" HOSE BARB	1	1
11	301062	MODIFIED FITTING	1	1
12	300989	TUBE HIGH PRESSURE OUTLET	1	1
13	300987	TUBE INLET	1	1
14	300986	TUBE RESERVOIR	1	1
15	111079	FITTING 1/4" NPT TO 1/4" COMPRESSION EL	1	1
16	110303	HOSE CLAMP	2	2
17	300984	MODIFIED BULKHEAD FITTING	2	2
18	111156	6G SYRINGE	1	1

## SEAL REPLACEMENT INSTRUCTIONS

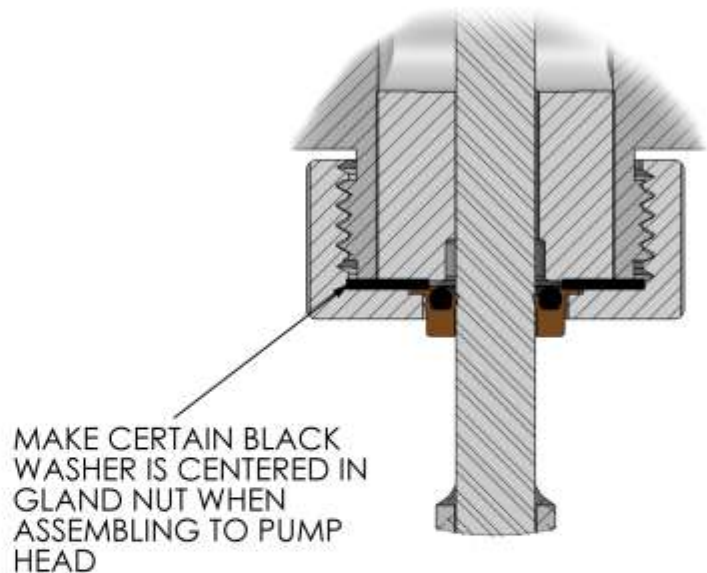
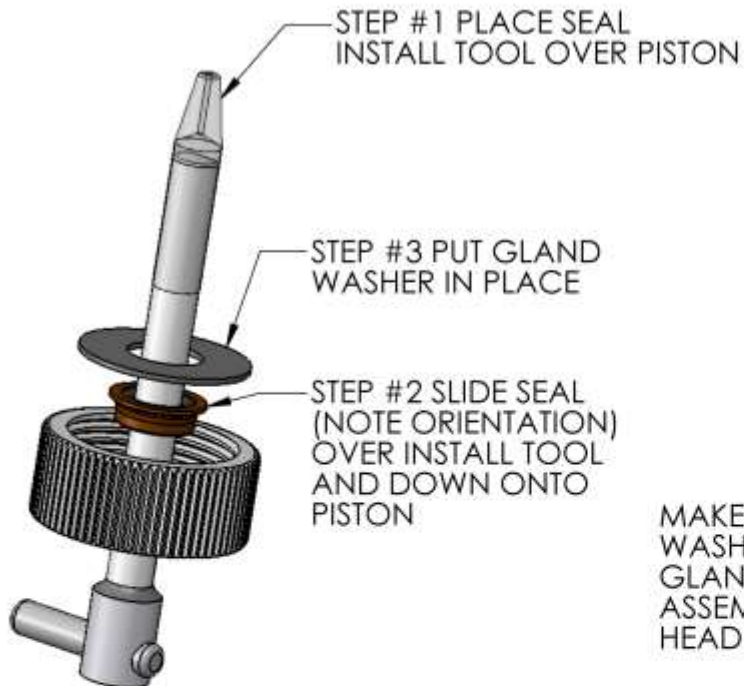



## Tips from the Field

The Chloritrol® has been dynamically tested, including the integrity of all internal fluid connections, prior to shipment. The C100A control unit is factory adjusted for optimum performance with the Chloritrol, and no additional adjustment of internal trim pots should be required.

However, if a newly installed Chloritrol® with C100A System fails to operate properly, the following is a step by step troubleshooting guide to determine the cause and corrective action.

When diagnosing problems with the Chloritrol® System, it should be first determined if the problem is related to the electronics circuit which includes C100 A, power supply, input control signal, and wiring. If the electronics appear to be operating properly, the fluidic circuit, which includes tubing, valving, fittings etc should be examined.

### First determine if the problem is Electronic or Fluidic.

- **If the motor is not rotating, begin with step 1 of ELECTRONICS.**
- **If the motor is rotating but no fluid is being pumped, proceed to step 1 of FLUIDICS.**

### ELECTRONICS:

- 1) With the C100A in the OFF position, rotate the rotary speed pot CCW to the "0" speed position.
- 2) Check all wiring connections between the C100A and the Chloritrol, and (if applicable) between the C100A and the 4-20 mA control source.
- 3) With the speed pot still in the "0" position, switch the power of the C100A to the "ON" position, which is the manual speed adjustment mode.
- 4) Increase the speed control CW gradually to a setting between 5 and 6 and observe the pump motor to see if it's rotating. **If "yes", go to step 1 of FLUIDICS.** If "NO", turn speed pot to "0", switch C100A to "OFF" position, and disconnect power.
- 5) Open the Chloritrol enclosure and see if the motor spindle (silver cylinder on right side of motor) rotates freely by hand. If "yes", continue to step 6. If "no", call factory.
- 6) With enclosure open, turn C100A to "on" position, set speed control to "5", and using a multi-tester, check the DC voltage at the terminal block of the Chloritrol®. The voltage should be between 30-40 volts. If "yes", call factory. If "no", check the power input to the Chloritrol® which should be 115V approximately. If "yes", check fuse. If "no", the power source is the problem.

### FLUIDICS:

#### Pump will not prime:

- 1) Verify proper mounting location relative to supply vessel according to Diagram 5.
- 2) If motor is rotating and no fluid is being pumped, check the inlet tubing to see if there is fluid in the tubing, and that the inlet bulkhead fitting (on the inside and outside inlet connections) is tight and not leaking air. If you observe that fluid level in the inlet tube rises properly to the bulkhead fitting, turn off power to the motor and watch the fluid level at the inlet tube. It should drop back momentarily when the motor stops, but should stop falling when observed for approximately 15 seconds. If the fluid continues to fall, there is a suction air leak, which must be corrected.
- 3) Make sure all valves on the inlet side (fluid source) are open, and that there is an adequate level of fluid in the supply vessel. Ensure that inlet tubing has not deformed due to suction (collapsed) whereby creating pump cavitation.
- 4) Check the mechanical flow setting of the fluid pump head (right side of motor) to make sure that it is set for a minimum of 10% stroke.
- 5) Make sure the tubing is sized correctly for the desired fluid flow. For flows below 500 ml/min, 1/4" OD tubing is recommended. For flows above 500 mL/min 3/8" - 1/2" ID tubing is recommended. Tubing sized too small, relative to flow, may cause cavitation problems, while tubing sized too large may cause vertical lift issues. Consult factory for additional recommendations.

#### Pump Primes but there is no fluid output:

Check tubing, connections and valving to make sure there are no closed valves or obstruction between the Chloritrol and the output destination (typically a groundwater well or water main).

